



# GAWGROUP

## NEWS FROM THE imteam GROUP

### ARTEC presents new plant concept



**GAWGROUP**  
www.gawgroup.com

**GAW**

**Ki** KRESTA industries

**osmo**  
membrane systems

**artec**  
AUSTRIAN RECYCLING TECHNOLOGY

**thomas**  
SPEDITION  
Gesellschaft m.b.H.

**ECON**

**UNICOR®**

Edition 2 | 2013  
limited edition

Shortcuts

Editorial

Company report

Projects

Competences

Focus on

People

### Shortcuts

#### Commissioning of the first enzymatic starch conversion plant in South America

In December 2013, GAW Brazil will be commissioning South America's first enzymatic starch conversion system at Jaepel Papeis e Embalagens, in the Federal State of Goiás (GO). This project will be a milestone for GAW Brazil and will certainly be a trailblazer for the use of enzymatic starch in the Brazilian paper and cardboard industry.

GAW Brazil's outlook is positive for 2014 also, since the Brazilian market is growing, especially in the packaging industry. "We are anticipating orders for 2 large projects in addition to the other projects for enzymatic starch conversion systems. We will also be structuring a useful partnership with a local starch supplier," explains Rafael Okubo, Managing Director of GAW Brazil.

#### Follow-up order "Gelling oven refurbishment" – Body Construction Audi Neckarsulm

The GAW plant supplied under the "Gelling oven refurbishment" project (report in the previous imteam edition) has been in operation at Audi Neckarsulm Body Construction since May 2013, as scheduled.

The Automotive team has since end September been working on the follow-up order to the "Gelling oven refurbishment" project.

The objective is to ensure additional optimisation and increased efficiency of the production plant in this section, well into the future.

Complete restructuring of the oven inlet and outlet, including new software and visualisation is planned, in addition to conventional conveyor system elements such as roller conveyors, cross chain conveyors, eccentric and scissor lift tables and extension of pallet storage by a stacking/de-stacking facility and fill level indication.

Changes and adaptation of the oven throughput conveying system and automatic arresting of oven pallets at the charging/release point to prevent movement during loading by forklift are also implemented within the scope of this project and are part of the delivery.

Installation is scheduled for winter 2013/14 plant shutdown, starting 21.12.2013.

### Editorial

Austria is doing damn well. We have survived the biggest economic crisis since World War II virtually unscathed. Austria ranks among the wealthiest countries worldwide, unemployment is extremely low and prosperity is redistributed more thoroughly than in hardly any other nation worldwide. According to the latest report on industrial competitiveness published by the EU Commission Austria, together with Germany, Denmark, Sweden and Luxembourg, ranks among these top five consistent top performers in the EU; Austrian companies are also highly innovative and boast excellently trained staff. And not to forget our reliable supply of electrical power and the top quality of our health system. This is not, however, an invitation to rest on our laurels since we are living off the fruits of the past and it is now high time to shoulder our responsibility towards the future. We must assume responsibility for the future of our children and grandchildren and address some questions: How much longer can we afford to expand the social and welfare state in the face of the far from resolved European debt crisis? How can we reduce our debts to a reasonably responsible level quickly and sustainably? How can we save our state pension system, which has by now finally assumed Ponzi scheme characteristics, from collapse? And are we prepared to continue simply shrugging our shoulders at the slow but steady decline of our country into the economic second league - under the motto "mediocre, but still there"?

Let us take another look at the first lines. Fact remains: Austria is doing well. Also a fact, however: Austria is capable of more – provided we aspire to compete with the world's best and can muster the necessary political will and courage to implement local political necessities fast and correctly.

It is natural in the Austrian corporate landscape to set our goals high. It has in this respect always been the stated objective of the GAWGroup to preserve our independence as a family-run business and to ensure the company's survival

in the longer term. Apart from organic growth, this is achieved also through targeted acquisitions. KRESTA industries, for instance, took a significant step along its consistent path towards full range supplier and know-how provider in the complex sector of industrial plant construction when it acquired majority shareholding in the German TRIPLAN AG this year and UNICOR's acquisition of ADESCOR Inc. was a further step towards expanding and developing its special plastics engineering department (read more about this on Page 2).

It furthermore gives me pleasure to report that extensions to the GAWGroup headquarters, which are also the GAW technologies GmbH

Graz headquarters, started in autumn 2012, have now reached final phase. I would like at this point also to express my appreciation to all the staff who, despite the often noisy building operations, steadfastly kept working and refused to be distracted.

On this note, I wish you and all imteam readers a quiet and peaceful Christmas and a healthy and prosperous 2014.

Mag. Jochen Pildner-Steinburg

#### The Editorial team

Above from left: Nina Pildner-Steinburg/GAW, Marc Pildner-Steinburg/GAW, Andreas Mühle/GAW, Josef Mohl/GAW E-Abteilung  
Middle from left: Christian Stine/GAW, Magdalena Deisl/ECON, Christian Steiner (OSMO), Rinco Albert (orange clou für UNICOR)  
Down from left: Oliver Koroschetz/GAW, Sigrid Tertinegg/GAW, Silke Thamerl/KRESTA, Jörg Severing/ARTEC



www.gaw.at



COMPANY  
REPORTGAWGroup Holding  
extends its group  
portfolio

Acquisition of German TRIPLAN AG  
and Canadian ADESCOR Inc.

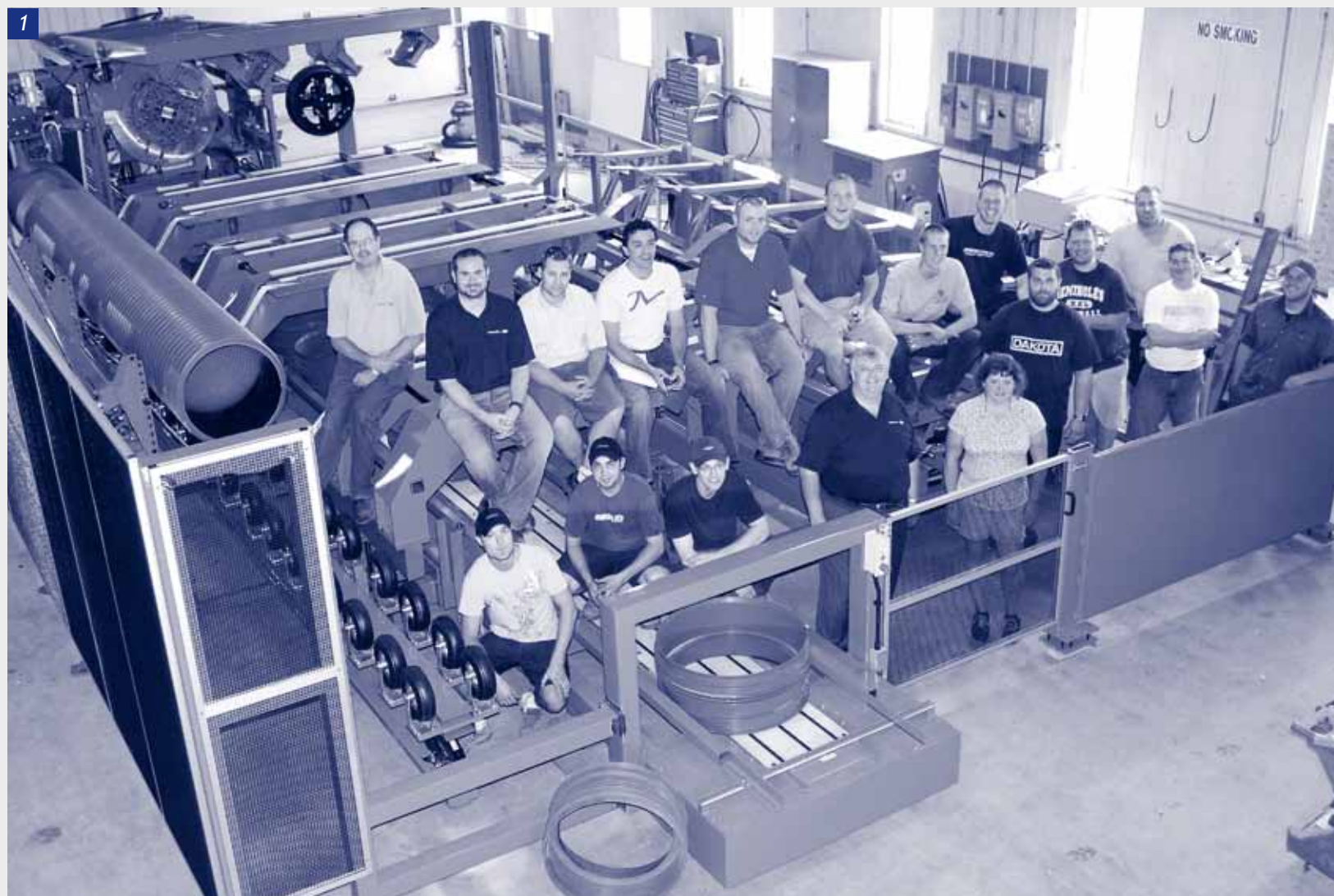

1 Team ADESCOR

2 TRIPLAN production plant



#### Engineering Services and Technology Services – TRIPLAN AG

In September of this year, in a significant step along its consistent path towards turn-key supplier and provider of know-how in the complex sector of industrial plant construction, KRESTA industries acquired majority shareholding in TRIPLAN AG, a company operating in the engineering and technology services business sectors.

TRIPLAN AG, headquartered in Bad Soden am Taunus, Germany, is a paragon of German technological advantage, supplying high-tech engineering services globally for the construction of complex production plants in the pharmaceutical, chemical and fine chemical, refinery, life science and energy sectors.

TRIPLAN AG, as an independent and impartial general and component designer, handles the engineering side of new and reconstruction projects, refurbishments and optimisations. The Technology Services department specialises in sector-specific IT solutions. These entail development and sales of high grade CAD/CAE applications and software for suppliers and installers in factory and plant construction. The Technology Services experts offer Product Lifecycle Management consulting, from analysis to solution.

TRIPLAN AG has been the general designer and strategic development partner of renowned customers such as Siemens, Novartis, Roche,

Alfa Laval and Daimler Chrysler since 1967. TRIPLAN AG today has a staff complement of more than 400 permanently employed engineers and has generated an EBIT of 1.02 million Euro from a turnover of 40.7 million Euro for the previous business year.

#### Downstream equipment for the plastic corrugated pipe industry – ADESCOR Inc.

With UNICOR GmbH's acquisition of majority shareholding in ADESCOR Inc., headquartered in Exeter (Ontario), Canada, the 100% family owned GAWGroup Holding Pildner-Steinburg GmbH took another step in the development of its special plastics machinery construction division.

ADESCOR Inc. develops, builds and distributes downstream equipment used in corrugated pipe extrusion plant (corrugators). ADS Leach Field, the largest corrugated pipe manufacturer in the US, counts among the renowned ADESCOR customers.

Majority shareholding is the consistent further development of the successful cooperation between the two companies over the years. UNICOR is thus able to strengthen its position in the North American market, offering products and services to meet the demands of the regional market. Integration in the UNICOR product portfolio will ensure internationalisation and global distribution of the ADESCOR range.

## PROJECTS

GAW – Major order from  
ASIA SYMBOL Rizhao

New coating kitchen  
supplies BM 12 and BM 13  
paperboard machines

**V**oith commissioned GAW technologies with the delivery of the wet end chemicals and workstations for the BM 12 and coating colour preparation for the BM 12 and BM 13 at ASIA SYMBOL Rizhao (part of the APRIL Group) in the province of Shandong/China.

Asia Pacific Resources International Limited (APRIL), founded in 1993, is one of the leading fibre / pulp and paper manufacturers and one of the world's largest producers of bleached hardwood kraft pulp. The integrated pulp and paperboard mill ASIA SYMBOL in Rizhao started commercial operations in 2005.

#### 4 coating colour mixers ensure flexibility in coating colour production

Paperboard machines 12 and 13 are supplied by a common coating kitchen, equipped with 4 coating colour mixers to ensure the special flexibility of the plant's coating colour production. A waste water treatment system will also be installed to minimise any environmental impact, especially since environmental protection is a significant part of GAW specifications and also a significant issue in the APRIL Group guidelines.

The new BM 12 paperboard machine will produce liquid packaging board for the food industry (relevant special hygiene standards will be in force during installation work also); the machine will be 4.6 meters wide and produce at a speed of 900 m/min. Start-up is planned for summer 2014.



# Thermosensitive coating colour preparation for Shouguang Chenming

The Chinese paper producer Shouguang Chenming Art Paper Co., Ltd – a subsidiary of Shandong Chenming Paper Holdings Limited, one of the largest paper producers in China – has commissioned GAW technologies with the supply of the coating kitchen complex for thermosensitive paper.

The Chenming Paper Group is listed on the China and Hong Kong stock exchanges and has more than 10 production sites, with an annual paper production capacity of 6 million tons.

## Thermopaper production needs special preparation of chemicals

The delivery includes the complete thermal coating kitchen complex for the refurbished

PM5 paper machine, designated in future to produce thermosensitive paper for end products such as tickets, tags, labels, lotto/gambling receipts etc. GAW is proud to once again put its technological know-how in the area of treatment plant to the test – in this case the elaborate treatment of special chemicals required in thermopaper production. All the equipment must be installed in existing buildings and plant to a very tight schedule: Delivery took place in October and commissioning is scheduled for February 2014.

GAW and Shandong Chenming can look back on many years of business relationships and many joint projects. Although the field of special paper production is new territory to Shandong

Chenming, they consider themselves in capable hands – not only is GAW bringing the requisite technological know-how about the preparation of thermally sensitive coating colours to the table, they are also the only supplier in this sector of the Chinese market.

## PROJECTS

# First order for GAW at VW Bratislava

GAW technologies has successfully implemented a vast number of larger and smaller projects in plant manufacture for the automobile industry over the past twenty years. The range of GAW products supplied to the automotive sector comprises, among other, elements of point-to-point conveying such as monorails (electrical and P&F) for car bodies, doors, engines etc., skid and push platform materials handling technology between the body shell, painting and final assembly production halls. GAW also supplies robot applications, jigs and fixtures, steel and piping construction for supply plant and special plant to customer specification vehicle manufacturer production facilities.

At the beginning of August, Volkswagen AG commissioned GAW technologies with rebuilding the handling systems at the Volkswagen works in Bratislava/Slovakia.

Volkswagen Slovakia, a.s., a subsidiary of Volkswagen AG, was founded in 1991, at that time under the name Volkswagen Bratislava. With a staff complement of around 9 400 today, Volkswagen Slovakia is one of the biggest Slovakian employers and one of the primary exporters of that country.

## Globally one of a kind – 5 vehicle brands under one roof

The models VW Touareg, Audi Q7, Volkswagen up!, Skoda Citigo, SEAT Mii and the Porsche

Cayenne autobodies are currently manufactured at the Bratislava works, rendering this site the only plant worldwide manufacturing 5 vehicle brands under one roof. Close on 420 000 vehicles were built in 2012, achieving a turnover of around 5.6 billion Euro. The external cable car used to transport vehicles within the automotive plant is a unique feature. It has a length of

452 metres, travels at 8.3 km/h and transports up to 1 100 vehicles per day.

GAW technologies has in the past successfully handled many projects for the Volkswagen Group in all fields of production, among other in Ingolstadt, Neckarsulm, Brussels, Győr and Hannover. The Bratislava works project will be the first of this kind for the materials handling team.

5 vehicle brands are manufactured under one roof at the VW Bratislava works. GAW has now been commissioned to rebuild the handling systems.

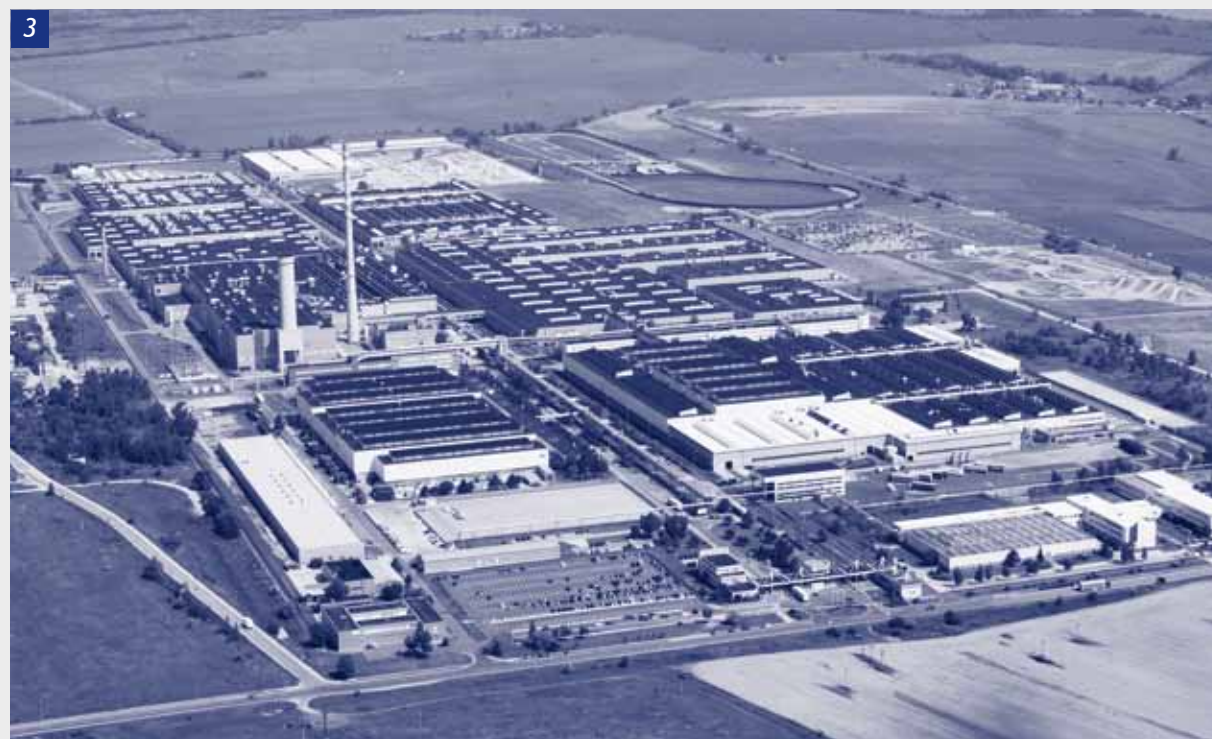

3 VW Bratislava works

# OSMO membrane water treatment plant for PALM Paper Limited

The PALM Paper Limited paper factory in King's Lynn, UK, commissioned OSMO Membrane Systems with the engineering and supply of a modern membrane water treatment plant within the framework of expanding existing water treatment facilities and improving the water quality supplied to downstream processes. OSMO developed an economic water treatment concept together with the customer. The delivered plant has been supplying the paper production machines and parts of the cooling circuit in the factory since autumn of this year. The new membrane plant supplements an existing smaller water treatment system, now connected downstream. The installed treatment system has a permeate output capacity of

450 m<sup>3</sup>/h, rendering the plant one of largest reverse osmosis plants installed in the UK to date, serving primarily to further optimise water circulation and to save costs.

## Water circulation optimisation and cost saving

The plant comprises a pre-filtering unit with partial redundancy at the inlet and with desalination through 3-line, 2-stage reverse osmosis. A permeate which has largely zero hardness and is low in salt is the result. The plant is fully automatic, reducing servicing by operating staff to topping up of dosing chemicals. As is conventional in many OSMO membrane plants, technical refinements such as

OSMO has developed a new water treatment concept jointly with the Palm paper factory in King's Lynn, UK. The plant started operating in autumn and is one of the largest reverse osmosis plants in the UK.

single bank rinsing and a CIP cleaning station are fully integrated here as well.

Due to limited space and the customer's request to utilise space as effectively as possible, the design is highly compact. Installation and commissioning time could also be reduced through supply of pre-assembled modules. The installed measuring systems (online Redox/pH/conductivity/through-flow measurements) allow targeted and economical dosing of the relevant components. Plant capacity may be increased relatively simply and quickly through the provision of additional pressure pipe zones which enable integration of additional modules.



## PROJECTS

## Kanaflex invests in a new UNICOR UC 1800

UNICOR in an interview with the new Brazilian customer Kanaflex, who has decided to invest in a UC 1800 for corrugated pipes up to 1800 mm outer diameter.

4 Tsutomu Nakabayashi, CEO Kanaflex



*Kanaflex CEO Tsutomu Nakabayashi responded to the questions*

*Mr. Nakabayashi, what are the Kanaflex goals with your investment in a UC 1800 from UNICOR?*

Kanaflex has been ranking among the market leaders in the production of HDPE cable conduits for 40 years. And Kanaflex also has a strong presence in the market for water and waste water pipes. The move towards large diameter corrugated pipes is in response to developments in Brazil, especially the expansion of infrastructure. Since these large pipes are a novelty on the local market and since specific standardised norms have been defined by the responsible ABNT authorities, we anticipate a huge demand for this product.

*How have you prepared yourself internally for the arrival of the new large corrugators?*

We are investing 50 million BRL in this project, mainly towards construction of a new production facility in the city of Itu (100 km from Sao Paulo). With 10 000 sq.m. production and 40 000 sq.m. free storage area, we have planned for adequate capacity also in the longer term. The first batches of pipes up to 600 mm ID

have been well received on the market since August 2013, meeting and confirming the expectations we had for this project. With delivery of the UNICOR production line, we will soon launch into the second project phase for pipes up to 1200 mm ID.

*After lengthy negotiations with several suppliers you in the end opted for UNICOR corrugators. What finally made the difference?*

We have been eyeing the production of large diameter corrugated pipes since 1998 already, allowing us to prepare well in advance and to study the technologies offered by various global suppliers in detail. We have to this end also visited various pipe manufacturers in Europe, Asia, the US and Latin America to get an impression of the different plant in production. We have prepared for this project intensively, as you can see, in order to now successfully implement it from a solid base. UNICOR was convincing especially as a European company which we trusted more than other manufacturers, quite apart from offering the best technical and economical solution. Also, the many years of company tradition and the prospect of cooperating with a strong and globally experienced team motivated us to successfully realise our vision jointly with UNICOR.

## From Mumbai to Pirdop – a special THOMAS transport

The Styrian logistics company was once again commissioned with the transport of a complete flue gas scrubbing plant.

5 A low bed on the way through Bulgaria

6 Boilers of the flue gas scrubbing plant



After successfully transporting a flue gas scrubbing plant from Mumbai to Singapore (imteam report in the 1/2013 edition), THOMAS once again organised a similar transport – this time from Mumbai (India) to Pirdop (Bulgaria).

**Moving inland under challenging conditions**

This shipment comprised 6 boilers on 40 ft flat racks measuring 11.7 x 6 x 6 m and weighing around 15 tons each, plus a number of extra 20 and 40 ft box containers.

The plant was shipped on the ZIM Europa from Nhava Sheva to Constanta, where it was transferred to a river boat and barges and continued down the Danube to Lom. Transporta-

tion from there on low beds for about 250 km inland to the Pirdop site took place under challenging conditions. The boilers travelled in convoys of 2. The first convoy required almost 3 weeks to cover this distance since, in addition to scheduled power outages, about 600 m<sup>3</sup> of branches, shrubs and trees needed to be removed.

Suitable partners were selected in India and Bulgaria based, as always, on criteria of best price/performance ratio and reliability. Freight forwarder THOMAS personally also supervised transshipment in Constanta.

The goods were delivered on site after a delivery time of almost 2 months – in good time, to everyone's satisfaction and without a problem.



# AIR cooling Made in Germany

The decisive factor in UNICOR's new development – the air-cooled UC 330 AC – were customer enquiries about efficient machines for the US drainage pipe market. Because especially air cooling is what American pipe manufacturers have always been looking for. UNICOR has now introduced its innovative in-house development based on the UC 175 corrugator.

The challenge of developing an alternative cooling system to tried and tested water cooling was a huge incentive to the UNICOR team. The aim, as always, was to satisfy maximum quality demands and the machine furthermore had to be simple to operate and also guarantee maximum output. And the result is a clear success, as the technical facts can demonstrate.

The machine covers a very wide nominal ID range from 2 to 10 inches, with a maximum OD of 330 mm. Machine performance is particularly outstanding in respect of single wall drainage products. In test-runs the nominal 4 inch ID, for instance, was produced with a weight of 460 g/m and a speed of 35 m/min. That comes up to an output of 965 kg per hour.

## Cooled air ideally controls form jaw temperatures

Cooled air continuously circulates through the form jaws. The air is cooled in an air/water heat exchanger, circulating through a closed circuit independent of operating and ambient temperatures. The temperature of the form jaw may be precisely controlled on the UC 330 AC touch display, between 20 and 80°C. Since the machine maintains the set temperature at all times, no further temperature adjustments are necessary in production.

Also the form jaw design considers the demands of the US pipe manufacturers. The form jaw length is precisely 4 inches to guarantee maximum compatibility with form jaws already existing in US corrugators.

In order to handle the high production speeds, the centre channel is particularly long. Especially in thick-walled single wall drainage pipes, it is imperative that

UNICOR makes a huge and innovative move for customers on the US drainage pipe market especially: The UC 330 AC with air cooling!

the thermal energy in the pipe is effectively dissipated. The total length of the form jaw chain is extensible by 5 pairs of form jaws, depending on requirements. It is therefore possible at any time to produce 6 or 12 meter pipes with an integrated shaped sleeve in the corrugator.

UNICOR is consolidating its excellent international reputation with the new UC 330. Through its innovative developments in both air- and water-cooled corrugators UNICOR is making a significant impact in the world market of corrugated pipe manufacturing technologies – setting new standards.

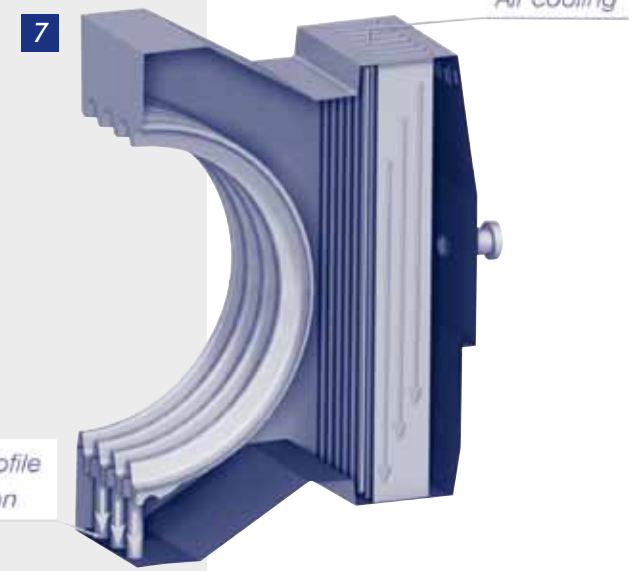

Single profile evacuation

7 The especially air cooling is effected at constant temperature

9

Technical Data UC 330 <sup>AC</sup>	
max. pipe diameter (outer diameter) in mm	330
min. pipe diameter (inner diameter) in mm	50
connection power in kw	2 x 18.2
number of mould blocks	123-128
chain length (mm)	12498.8-13004.8
closed chain length (mm)	5580
max. PVC output (kg/h)	1300
max. PP/PE output (kg/h)	1100
max. speed (m/min)	40
length (mm)	10500
width (mm)	2450
height (mm)	2572
weight without mould blocks (kg)	19000

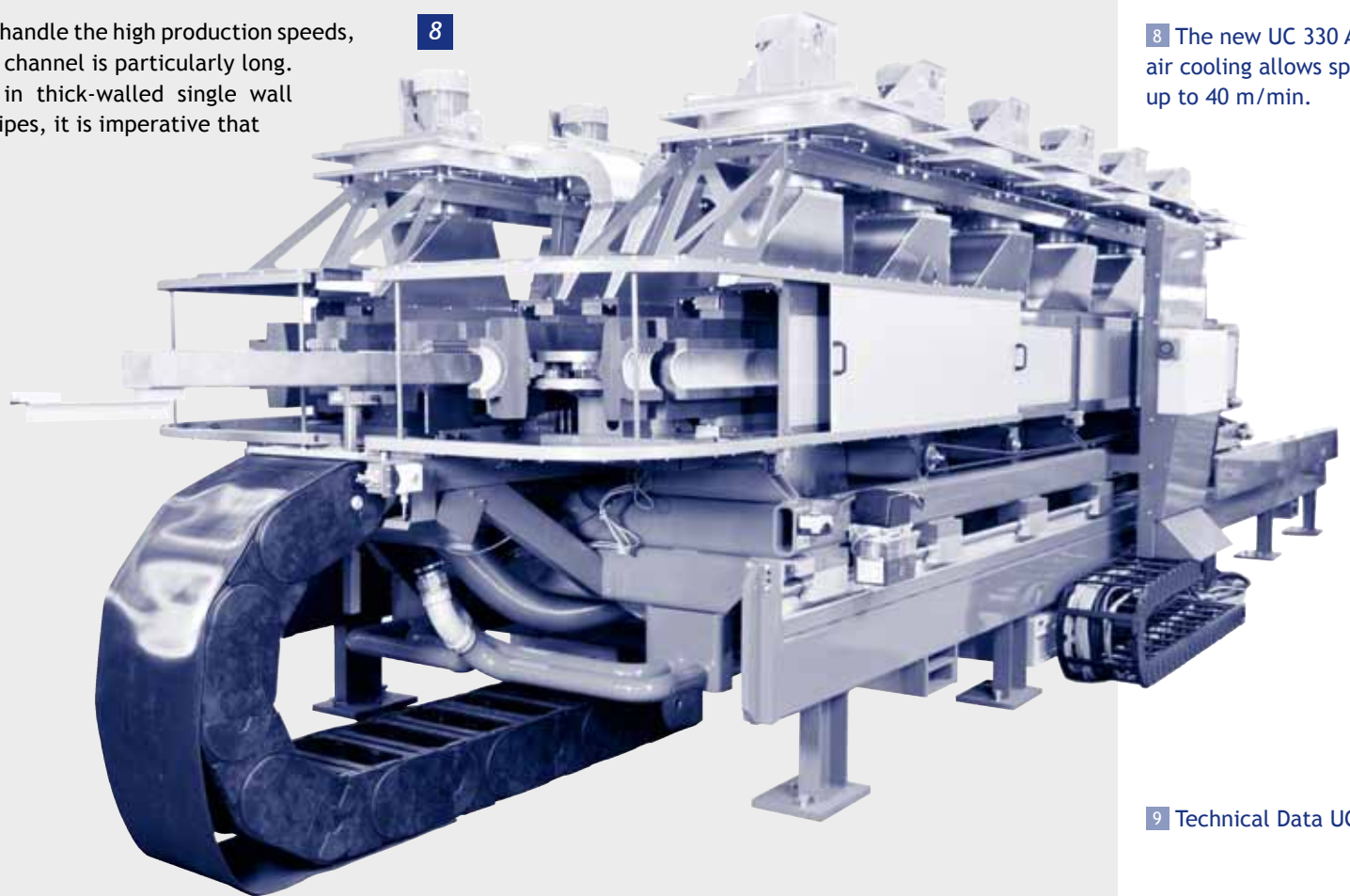

8 The new UC 330 AC with air cooling allows speeds up to 40 m/min.

9 Technical Data UC 330 AC

# Edelweiss Technology – THE new extrusion concept

The new “Edelweiss” extrusion concept combines recycling and compounding into a single process, achieving throughputs between 300 and 2 500 kg/h. This concept combines ARTEC treatment technologies with KraussMaffei Berstorff twin screw extrusion technology.

## ARTEC recycling know-how

ARTEC contributes its treatment technology comprising cutter compactor with de-humidification function, single-screw extruder with degassing system and individually adjusted filter technology to the partnership. A set of rotating knives in the drum shaped cutter compactor grinds and compacts and, thanks to the simultaneously generated frictional heat, automatically dries the foil and fibre material fed from an upstream washing system (with up to 12% moisture) and also ground material. The centrifugal forces in the cutter compactor feed the material flakes into the tangentially connected single-screw extruder where they are plasticised and homogenised. This is true for all types of thermoplastic plastics in any processed form.

On its way through the extruder the plastic melt passes one or more degassing zones in a vacuum, where now gaseous foreign materials and low-molecular polymer content are suctioned off. The plastic melt, still containing impurities, then flows through a continuously operating high performance melt filter.

## KraussMaffei Berstorff compounding competence

Using a melt pump, the now beneficiated and highly purified plastic melt is dosed into the ZE twin-screw extruder at constant pressure and volume either from the top or from the side. This is where the decisive refining process for production of high-grade compounds now takes place, based on the many years of experience and know how the twin-screw specialists from Hanover has in compounding.

The recycle melt is dosed with specific additives such as mineral fillers, reinforcing fibres, master colour batches, etc. This allows, for example, for recycled foil to be produced in virtually new material quality, with up to 70% - 80% CaCO<sub>3</sub> blow film compounds with a high filler content.

The two-stage process variation optimally exploits the twin-screw extruder's excellent compounding performance, even with high filler levels, and elegantly sidesteps the problem of dosing high volume incoming material, since pre-drying and densification takes place in the cutter compactor - single screw extruder combination.

A strategic partnership with ARTEC as a recycling plant specialist and KraussMaffei Berstorff as a manufacturer of extrusion plant is opening up radically new possibilities in recycling and compounding.

## Maximum plant flexibility: Combined as well as independent operation

Apart from improving the energy balance in the material cycle, this new technology also minimises shear energy during plasticising and clearly increases material quality, since process integration obviates the need to re-heat the ingredients. Recycling and compounding plant are in addition capable of operating independently of each other or in combination.

## For more information please contact:

Hagen Mosser  
Head of engineering, ARTEC  
Phone: +43 7228 6979-28  
e-mail: hagen.mosser@artec.at

Ralf J. Dahl  
Head of twin screw technology, KraussMaffei  
Phone: +49 511 5702 518  
e-mail: ralf.j.dahl@kraussmaffei.com

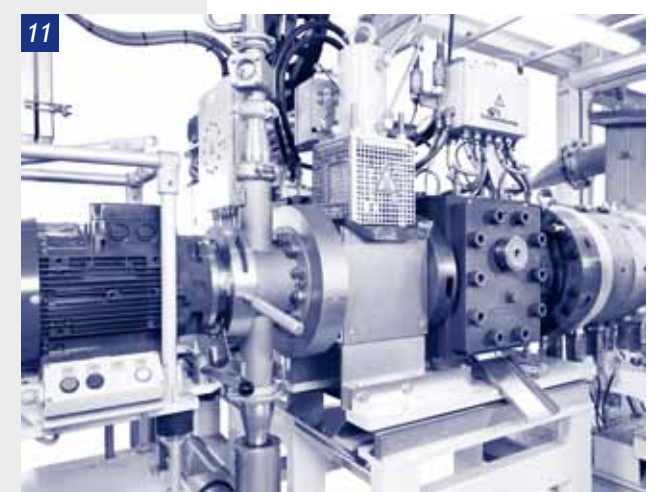

10 Twin screw extruder

11 Plastics recycling plant





## COMPETENCES

## Modular plant concept for the recycling industry

**M**odularity – ARTEC’s catchword for the future. From material supply to cutter compactor, extruder, degassing, filtration and granulation – these are the six components based on which the overall concept for any specific application can be defined.

### Increased energy efficiency and output

“We have tried, tested and improved every single component,” states Technical Director,

Hagen Mosser. Material infeed is fully automatic, independent of the filling level of the cutter compactor. The cutter compactor shreds the incoming material and heats it up to just under its agglomeration point. The residual moisture evaporates. ARTEC has further developed the extruder screw geometry to increase energy efficiency. Modular design allows extension of the extrusion unit by several degassing zones. Filters may be changed without interrupting produc-

tion thanks to twin- and multi-plunger strainer exchange systems. Granulation is also adapted to suit customer requirements and all the basic functions are available in one plant control panel.

ARTEC assembles its recycling machines individually and tailored to meet the needs of a specific customer, thereby achieving improved energy efficiency and higher output.

## MechMess – the new mechatronic cutter adjustment

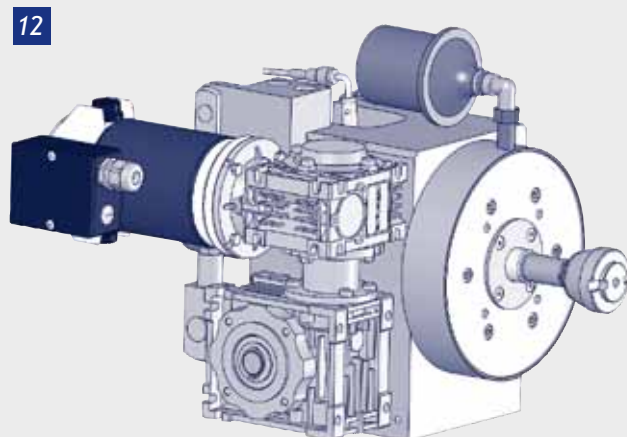

12

12 Cutter adjustment

**E**CON develops, manufactures and distributes underwater granulation plant for the global market. These machines press a plastic melt through a perforated disc which is then cooled down by the water in the granulation housing. A rotating cutter head cuts the solidifying plastic melt as it exits the perforated

disc and the pellets are then carried away in the circulating water. In prior art systems, the cutter head is pressed against the perforated disc by a pneumatically driven cylinder. This led to annoying vibrations under some operating conditions, because the system was not rigid enough.

In the course of the cluster cooperation project and with the participation of research partners ATP (Antriebstechnik Peissl GmbH) and LCM (Linz Center of Mechatronics GmbH), a new cutter adjustment system was developed. As opposed to previous solutions, the new system is based on a twin-screw gearbox with torque support which presses the cutter head against the perforated disc with a defined force. The high mechanical rigidity of the system prevents vibration in the relevant rpm range and the contact pressure can always be optimally regulated to maintain the perforated disc cutter system in optimal operating condition.

ECON’s newly developed cutter adjustment system increases underwater granulation plant efficiency

### New cutter adjustment keeps perforated disc cutter systems in optimal operating condition

It is foreseeable that the new mechatronic cutter adjustment will be more costly compared to previous pneumatic arrangements. It is safe to assume, however, that the anticipated advantages of the new solution will increase efficiency compared to previous solutions:

- Longer cutter service life
- Longer perforated disc service life
- Sustainable improvement of pellet quality
- Reduced power consumption due to reduced friction

Future planning includes rolling out the new solution to include all ECON underwater granulation plant design sizes, both for new plant and as retrofits to existing plant.

13 Underwater granulation plant EUP 10

## The new EUP 10 – from model to laboratory plant

**S**mall enough to fit onto any desk, the EUP 10 only weighs about 80 kg. The little underwater granulation system was actually built just for an exhibition. Designed for compact size, the EUP 10 was intended primarily for exhibit at foreign trade fairs to demonstrate the larger underwater granulation plant.

It became interesting in the course of the development to see whether this tiny plant could actually work. And it did! The EUP 10, depending on design and material, manages between 1 and 30 kg/h. This may even be increased to 50kg/h for some materials.

### Ideal for processing small volumes

Customers have also expressed great interest in the EUP 10. ECON has obviously found a market niche here. The EUP 10 is of interest especially for laboratory applications, where the required throughput is often quite small. This allows materials to be tested of which only a few kilograms are often available. Purchasing may come at a considerable cost for some materials and the option of processing small quantities only might be an attractive solution to many companies.

Despite its size and simplified design, the EUP 10 nevertheless offers all the advantages of the patented thermal separation. As in the larger ECON underwater granulation systems, this also prevents “freezing” of the melt in the exit holes, for instance.

The EUP 10 was officially introduced to a wide range of interested parties on the K-fair in October and the expectations in terms of enquiries have been exceeded by far. Due to the large demand, the little laboratory plant

is now series-manufactured. It will not be long before several EUP 10 underwater granulation systems will be shipped worldwide.



13

# GAW-sXF breaker

The sXF breaker (static cross-flow-breaker) extends the range of flow guidance systems by another static type. As opposed to the recently introduced aXF, the sXF is not driven. Pneumatic height adjustment ensures correct positioning for the process step.

Suitable for low to medium viscosity media, the simple means of adjusting the required flow through continuous adjustment of the individual X-flow blades will improve homogeneity and reduce undesirable air intake.

The sXF breaker will also reduce the energy demand by dint of its guided flow which, as opposed to conventional baffles, will divert media flow without turbulent disruption.

The sXF breaker has a modular design and may replace conventional baffles as a simple retrofit, since it may be mounted on the existing baffle structure.

### GAW-sXF static X-Flow breaker

#### benefits:

- customizable turnover
- improves homogeneity
- easy adjustable
- flexible usage depending on process parameters
- enhanced Applications
- high compatibility and easy retrofitting

Guided flow reduces energy consumption.

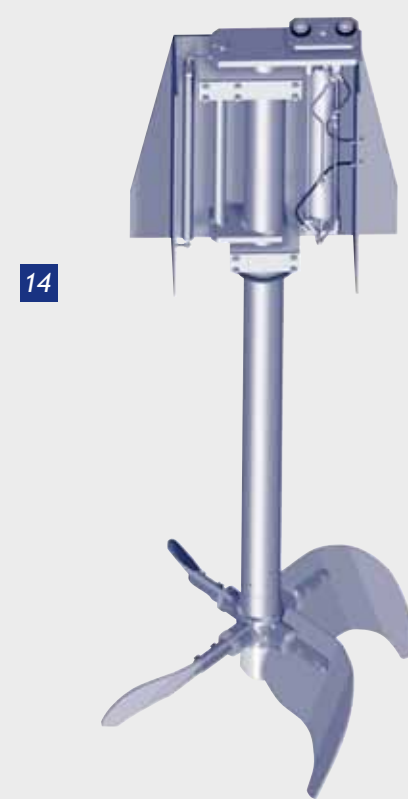

14

## COMPETENCES

14 GAW-sXF breaker

# GAW membrane deaerator for effective curtain coating

Sensitive coating combinations and shear-sensitive binding agents and colours which must not change with temperature are hardly manageable using conventional deaeration units and the situation gets particularly delicate when a curtain coater must apply a coating for which the exclusion of air is absolutely mandatory.

### Coating colour without air through online deaeration

The new GAW deaeration system operates from the coating supply container directly to the curtain nozzle, enabling complete deaeration of all colours used in paper coating and

likewise in inkjets, developer solutions, emulsions and oils. An incredibly large surface area is available here, despite minimal space requirements. The colour circulates around hollow fibre polyolefin tubes which are resistant to chemicals and deaerate already at minimal vacuum. This exerts no shear on the coating colour, allowing it to retain the chemical and physical characteristics as intended in the formulation. Using the new technology, particularly critical coating colours may be deaerated offline already, before use.

New deaeration technology for sensitive coating formulations.

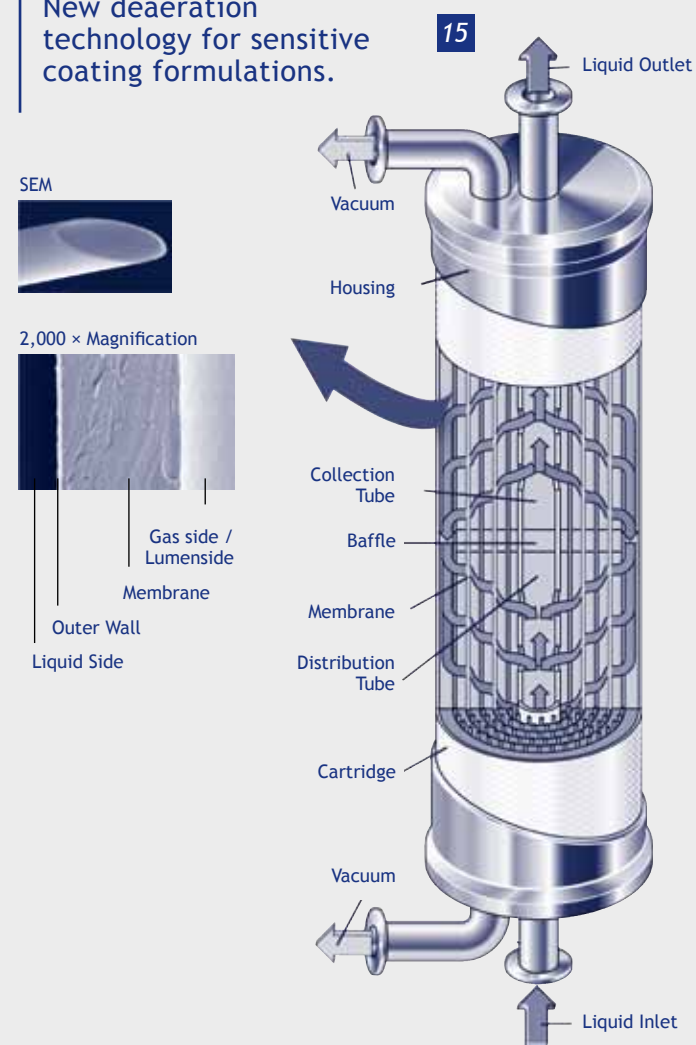

15

15 Principle of the GAW membrane deaerator

# BCT – The Buss Loop® reactor

It is assumed when analysing reactions between gases and liquids that the reaction occurs in one phase only. To react with each other therefore, one of the components must change phase and travel inside the second phase, where it will be available to the reaction.

### Principle of operation of the Buss Loop® reactor

The Buss Loop® reactor of Buss ChemTech AG comprises a reaction autoclave, a circulation pump, a heat exchanger and a reaction mixer (venturi nozzle). This system therefore has the same number of elements as a stirrer tank plant, but arranged differently:

- The reaction mixer is a high performance gassing apparatus comprising four main parts: An optional swirling system guides, orients and stabilises the introduced liquid flow. The liquid then proceeds through a nozzle generating a high speed jet and a venturi effect drawing gas into the suction chamber (gas circuit). A highly dynamic zone is created in the downstream mixing tube, with rapid dissipation of kinetic energy and intensive and highly turbulent mixing, creating very fine gas/liquid dispersion. This two-phase mixture is then pumped into the reaction tank fluid.
- The reaction tank does not need interior fittings such as baffles, cooling fins, etc. Since it is generally designed with a greater L/D ratio than a stirrer tank, it is more cost-effective, especially for high pressure

reactions. Injection of the two-phase dispersion again intensifies the mixing effect to achieve a very high mass transfer due to the high specific surface area of the tiny bubbles.

- The heat exchanger outside the reaction vessel is not limited by the level of the fluid in the reactor and may be designed as large as the process requires. The full heat exchanger surface is therefore available even should the reactor be operated at reduced capacity (e.g. a semi-batch process).
- Using a circulation pump instead of a stirrer allows higher transfer of power per working volume (kW/m<sup>3</sup>), again increasing the rate of mass transfer. Fluids with a high solids content and with gas loading up to 30% by volume can in this way be conveyed without problems of cavitation. This causes a further exchange of mass in both the reaction vessel and the loop pipe, with optimal transfer of energy to the gas-liquid dispersion. This ensures a perfect mixing effect and effective mass exchange throughout the reaction volume.

The perfect technology for gas-liquid reactions.

### The Buss Loop® reactor

#### benefits:

- High dissipation of energy
- Simple conversion from batch to continuous operation
- Consistent product quality
- Maximum environmental and safety standard
- Operating cost savings

16

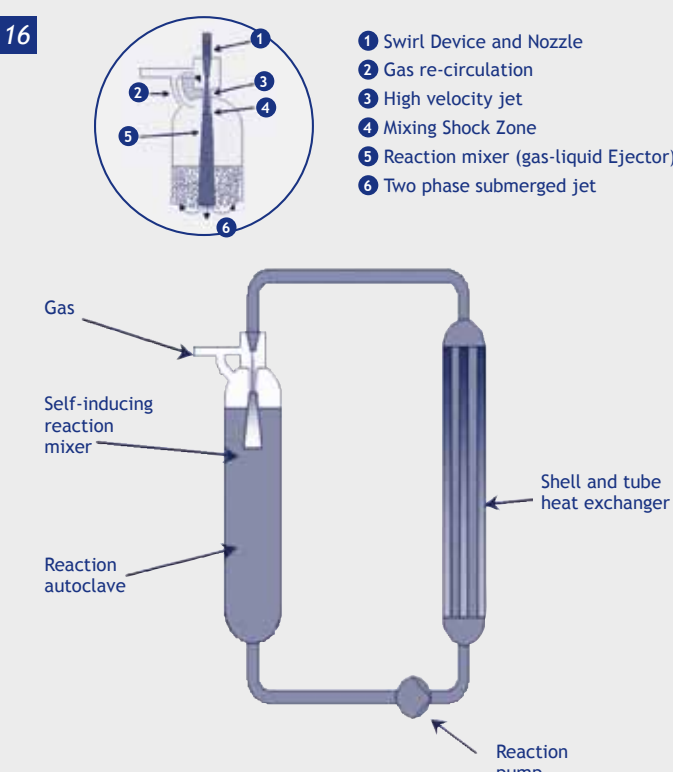

16 Functional principle of the Buss Loop® reactor



## FOCUS ON

# GAWGroup at the K – the highlight of the plastics industry sector

The K – the world's largest trade fair for the plastics industry opens its gates once every 3 years. With UNICOR, ECON and ARTEC, three of the GAWGroup of companies were represented on this occasion.

17 UNICOR and ADESCOR together at the K

## UNICOR places accents on Premium

Clearly more visitors from the trade – including virtually all the important players of the international market for corrugated tubes – and many detailed technical discussions and important conclusions. This is the consistently positive UNICOR GmbH résumé. “We experienced one of the best K shows in 2013. Hardly ever on previous plastics trade fairs has UNICOR enjoyed this level of interest. We were able to initiate important new projects and bring existing projects closer to conclusion. We are particularly pleased that our emphasis on top quality and service was very favourably received by pipe manufacturers worldwide. Our long-term promise of quality for premium quality products therefore rests on very strong foundations which our customers across the world may rely on,” reflects Managing Director Dipl. Ing. Klaus Kaufmann.

## Innovations in corrugated pipe manufacture: Air cooling concept and fast-change injection head

The new UC 330 corrugator with its newly developed air cooling system was presented, among other, which is expected to find applications mainly on the US drainage pipe market (see Page 5 for more on this), as well as the new “SWESY” injection head which ensures constant quality at lowest possible pipe weights. SWESY is the perfect complement to the “disc die heads” already on offer at UNICOR. Not only is it promising the users exceptionally high pipe quality with excellent distribution of wall strengths in the diameter ranges 95 mm ID to 700 mm OD, but extremely fast change of dimensions also translates to significantly increased productivity overall. The different SWESY 700 nozzle sets are fully interchangeable within minutes and the time consuming readjustment of the injection head centre after a change falls away.

The Canadian company ADESCOR, part of the UNICOR Group since 2013, was present with several of its staff exhibiting its product portfolio of many further developments in corrugated pipe manufacture.

18 „Pelletizing is our DNA” – the motto of ECON

19 Numerous interested visitors at the stand of ARTEC



## ECON: “Pelletizing is in our DNA”

ECON was present at the K with a contingent of 11 at its stand under the new slogan “Pelletizing is in our DNA”. Apart from the many existing customers, many new contacts showing a keen interest in ECON technology were also forged and business transactions concluded directly at the fair are particularly satisfying.

## EUP 10 as an attraction

The new underwater granulation system for application in laboratories, the EUP 10, was the centre of particular attraction. The visitors were extremely impressed by the model sized plant and more than just one would have loved to take the machine home right away (read more about this on Page 6).

A live demonstration with the EUP 150 underwater granulation system was also on the programme twice a day. Leistritz made avail-

able a double screw extruder for this purpose. Numerous interested visitors gathered around the stand daily at 11:30 and 15:30, enthusing about the (of course) perfectly operating plant and its ECON technology to the accompaniment of music and explanation. Especially the simple and uncomplicated start-up procedure convinced all and sundry.

## ARTEC and the red-white-red butterfly

The new ARTEC company image created considerable food for discussion among the exhibitors and visitors at the fair: a butterfly in the

red-white-red colours of the Republic of Austria is the “heraldic animal” symbolising the caring treatment of resources, environment and energy. The Austrian roots of the company were also emphasised again in the new logo.

## Many parts create a whole

Especially the new MODUL machine concept, however, attracted more than 400 interested visitors. This is a modular recycling plant configurable to suit specific customer needs and ensuring resource and energy saving material processing. (read more about this on Page 6)





# News from the Lavant valley

The great Ki festival took place in "the factory" once again in September, finding great appeal among the staff. Everyone was invited: from KRESTA and PAMA, KWE, EICKHOFF and KMM to BCT and many staff made use of the opportunity to exchange views and forge new friendships in a convivial atmosphere outside working hours. And those present heard from the horse's mouth that the Group of companies has grown once again: "The acquisition of TRIPLAN AG, a leading engineering partner in the industry with about 400 engineers, is the consistent continuation of the growth strategy of recent years and represents a significant step in the further development of the Group as a turnkey and know-how provider in the field of plant construction," says Franz Kreuzer, CEO of KRESTA industries.

**Servus – Willkommen – Gruezi**  
[Hallo – Welcome – Greetings]

This was the standard greeting already in October as the Directors and Branch Managers of TRIPLAN AG met at the St. Andrä location. Apart from company presentations and a works visit, the programme included especially coordination on management level in order to enable perfect Group integration.

### Further extensions to the location

After Ki added extensions to its location in St. Andrä a number of years ago, it is now such



time again. The investment in the double digit millions kicked off in October. The office block for Engineering, Ki-IT, Competence Centre and Commercial Management was extended in the first building phase and moving in is planned for end of February already. Building phase 2 comprises extensions to Production and relocation of Finishing is planned for spring 2014.

Kresta industries had its hands full with a comprehensive programme of events in autumn.

## FOCUS ON

20 Ki festival

21 The Directors of TRIPLAN AG met at the St.Andrä location

22 KRESTA extends its location at St.Andrä



# THOMAS: New kind of transport insurance

This is unfortunately nothing new – ships will occasionally be delayed. Shipping companies accept no liability for resulting damages. But who pays the airfreight for replacements

which the recipient may need to assure continued production? Since the customer has been paying to date, freight forwarder Thomas has now decided to offer an insurance enabling

An insurance against delayed ships.

the customer to insure himself against these damages. Please contact us should you wish to learn more about this insurance.

# First industrial technician at GAW

Technology is exciting. Technology is fascinating. Technology offers great jobs.

And: Technology means helping to shape the future. The apprenticeship, which since 2007 may be complemented with a qualification as industrial technician, offers first class training in this respect. An exciting career path with abundant opportunities which is also offered by many companies in the Styrian industry.

### Diploma awards ceremony

After completion of his apprenticeship as technical draughtsman, followed by training as foreman and the high school diploma,

Stephan Weber was finally on 11 November, 2013, presented with his hard earned diploma as Industrial Technician by Dr. Gottfried Maresch, Chairman of the Board of Leder & Schuh AG and leader of the working group Bildung der IV-Steiermark [Education of the IV-Styria].

GAW is very proud of its young team member who, in addition to his activity as CAD designer and his training as Industrial Technician, has already personally assumed responsibility as apprentice trainer. GAW is ready to support Mr. Weber in the planning of his future career.

Stephan Weber was awarded the Industrietechniker [Industrial Technician] diploma in November.

23 Stephan Weber (middle), his parents and partner Sabrina together with Wolfgang Senner, Nina Pildner-Steinburg and Andreas Gangl





## FOCUS ON

# Austria. The best place to be born.

The Newsweek magazine posed an extremely tantalizing question in 2010: If you were born today, which country would provide you the very best opportunity to live a healthy, safe, reasonably prosperous and upwardly mobile life? Or putting it differently: Which country worldwide is offering those born today and in future the best framework conditions for sustained good quality of life? In the analysis of the response to this question, Austria ranked 18th. The first three places went to Finland, Switzerland and Sweden.

The Bertelsmann Foundation published a study titled "Generational Fairness in Ageing Societies" in the summer of 2013. Austria did not do well in this comparison of OECD states either, occupying position 20 among 29 countries in the analysis of state social expenditure distribution among old and young.

Any ranking may of course be questioned and the selection and weighting of individual factors is not cast in stone. It is cause for concern, however, that our country is never near the top in international comparisons rating the opportunities of the young. The one exception, which we would like to highlight as particularly encouraging, is in the comparison of youth unemployment. Labour market data shows that the employment rate of young people in Austria is higher than in any other EU country. Discussions of the question whether this is the case "because of" or "despite" the educational standard of graduates of the Austrian educational system would be outside the present scope. It is an internationally recognised fact, however, that Austrian companies, known to train over 40 percent of an age group as apprentices in a dual system, can explain the difference between countries.

## 9000 learners annually leave the Austrian educational system without a qualification

Back to the rankings: If a country performs no better than average in virtually all rankings, then this generally cannot be attributed to the selection of criteria on which the evaluation is based. But, being aware of our responsibility towards future generations, we cannot and dare not accept mediocrity. The first step to take in this respect is that we, the Austrians, should accept the fundamental challenge that Austria must change to become the country with the best framework conditions for young people.

Investment in the talents of the young is the salient key to success. The starting point is simply asking about the tendencies, interests and talents of the young and searching for ways of accommodating these educational and professional preferences. One of the most important elements of successful personal development is the comprehensive preparation for a profession, oriented to reflect the talents and interests of the young as well as the regional economic options. The objective should therefore be to place young persons' individual perspectives on life, their talents and ambitions in the focal point of educational institutions. Too many youngsters are leaving the Austrian educational system every year without being adequately prepared for the questions of further education and a career. The uncertainties are enormous - no matter whether the change in educational direction occurs at the defined system interfaces or in the form of "abandonment". 9000 learners between the ages of 15 and 19 are abandoning the Austrian educational system each year without a qualification.

## Accepting the responsibility for young people

Accepting responsibility for the young would mean optimisation and professionalisation of the career orientation process in Austria to

Assuming responsibility for the youth means not to be satisfied with mediocrity.

thereby clearly reduce this number - one of the most significant and urgent fields of action for those responsible for Austrian educational policy.

Accepting responsibility for the youth also involves action in terms of the clearly documented further needs in the field of education. The significance of the PISA rankings are also discussed in this country at length (would this also be the case if we were ranked better?). Once again, however: mediocre to bad results in all rankings say more about the quality of the surveyed system than about the ranking itself. About 30% of 15-year-olds cannot comprehend what they read. What is the perspective we would like these youngsters to have on society? How will we succeed in integrating these youngsters into a working world in which the demands are constantly increasing? What individual dramas are played out every year due to this situation - generally hardly a topic of debate? What kind of society are we heading towards as we ignore these facts?

The Austrian socio- and politico-economic status quo is relatively intact. It would be a grave error of judgement to assume that this situation will naturally continue into the future. The same applies to those who believe they have no primary responsibility of including future opportunities of the young in the design of today's framework conditions. If we are satisfied with mediocrity, then the beginning of the end of the social development which turned Austria into a wealthy country worth living in is in sight. In the interest of the younger generation and our responsibility towards them, we should therefore do everything in our power to ensure that one day the answer to the question "If you were born today, which country would provide you the very best opportunity to live a healthy, safe, reasonably prosperous and upwardly mobile life?" will be "Austria".

## People

### IMPRINT

**Publisher**  
GAWGROUP, GAW technologies GmbH,  
Puchstraße 76, 8020 Graz

**Pictures**  
Submitted by the individual companies

**Layout/Design/Editorial office**  
PICHLER-JESSENKO  
Mag. Alexandra Pichler-Jessenko  
Agency for Market Research and Communication

**Print**  
Print & Art Faksimile GmbH

Typographical and printing errors excepted

**Website:**  
<http://www.gaw.at/de/aktuelles/gaw-group-zeitung.html>

<http://www.gaw.at/en/current/gaw-group-newspaper.html>



[www.gaw.at](http://www.gaw.at)

GAWGROUP



**Rafael Okubo**  
CEO GAW Brazil

Rafael Okubo completed his studies in chemical process technology at the USP University of São Paulo and followed this up with a Master's degree in strategic management. After working in the fields of processing, sales and customer service for multinational companies such as Akzo Nobel Chemicals, Oxiteno, Cognis and Monsanto, he started his career at GAW Brazil in 2008 as process engineer and project manager.

#### Contact:

E-Mail: [okubo.rafael@gaw.at](mailto:okubo.rafael@gaw.at)  
Tel.: 0055 (11) 5052-1851



#### The GAW Brazil team

The GAW SISTEMAS E TECNOLOGIA DE PREPARACAO DE ADITIVOS PARA INDUSTRIA DE PAPEL E CELULOSE LTDA team (in this picture with Adam Glowacki, CEO GAW PCS.) has in past years worked primarily on projects for International Paper as well as for Celulose Irani, Novacki, MWV Rigesa, Suzano Pulp and Paper, Jaepel, etc.



**Mag. Angela Kramer**  
Head of HR-Department  
KRESTA industries

Angela Kramer has been with KRESTA industries since 2012, where she has since then been in charge of the Group Human Resources Department. The Group has a staff complement close on 1100, all of these under the comprehensive care of Kramer and her international team - from appointment, via training and further education to resignation from the company. The HR Department considers its natural function as that of a "bridge between staff and management and also as a business partner to the individual departments".

As a graduate of studies in general business administration, Kramer is well aware of the important impact of personnel resources on the success of a company and is constantly striving to improve the effectiveness of procedures and processes in the company.

#### Contact:

E-Mail: [angela.kramer@kresta-industries.com](mailto:angela.kramer@kresta-industries.com)  
Tel.: 0043 (0)4358 3811 -215